

LEGRAND EGYPT **COMPANY PROFILE**



 **legrand**[®]



SAFETY FIRST

Your safety is our main concern. We protect you and your family every day from electric hazards.



UNIVERSAL SOLUTION

More than 300 functionalities to cover all your lighting, safety, data communications & energy saving needs.



COMFORT & PEACE OF MIND

Sophisticated yet easy to use devices such as sensors and dimmers, will allow you to take complete control over your home, making your life easier than ever.



ISO 9001
BUREAU VERITAS
Certification



ISO 14001
BUREAU VERITAS
Certification





INDEX

1. About Legrand	4
2. Product Lines	6
2.1. Power & Protection	6
2.2. UPS Products	18
2.3. GREEN'UP Access & Premium Charging Solutions for Electric Vehicles	28
2.4. Structured Cabling and Solutions for Lans & Datacenters	32
2.5. Cable Management and Power and Data Distribution	38
2.6. Lighting Control	46
2.7. Wiring Devices	50
2.8. Smart Home	56
2.9. Controlling the Installation	60
2.10. Hospitality Building	66
2.11. Healthcare Solutions	70



ABOUT LEGRAND

Legrand is a multi-brand company that has been supplying for over 60 years all the blended electric solutions for the management of building functions such as lighting, heating, energy, networks and access control.

The Legrand Group is the owning company for Bticino & Legrand Egypt (EMB Electrical Industries S.A.E.). The Company thrives from the Group's unceasing day-to-day research in order to adhere with global standards, to always acquire and provide the best solutions to our clients. With Legrand's cutting-edge product design and selection variety, the company aims to keep expanding its services worldwide by developing its efficient relation with investors, architects and consultants.

Approximately two-third of sales are made with products ranking No. 1 or No. 2 on their market, including several prominent positions in France, Italy, U.S.A. , Brazil, Russia, India, China, Mexico, and Egypt, committed to our international standards, and that qualified Legrand for over than 50 years in Egypt.

Legrand's company progressed to become today a global innovator in electrical and digital building infrastructures, to ensure full service to the market, legrand is committed to working closely and efficiently with investors, architects and consultants.

Legrand Egypt awarded (GEEIS) certification (Gender Equality European & International Standard Diversity label) created by Arboru.

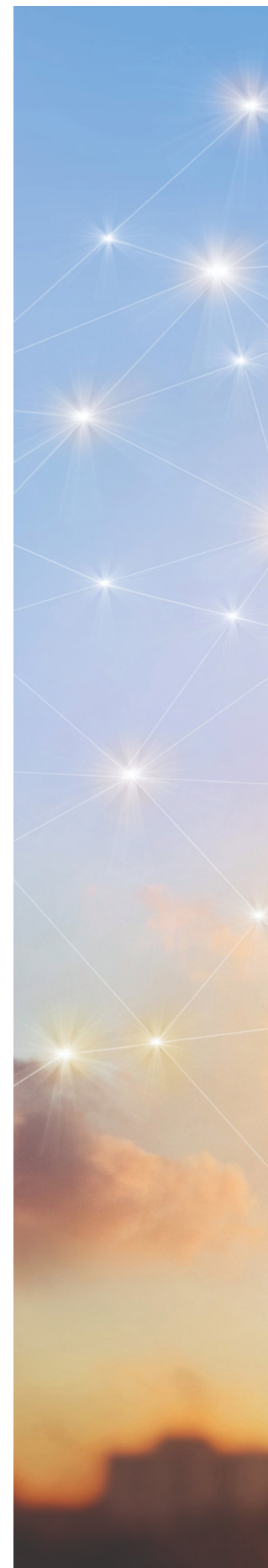



POWER & PROTECTION

To ensure effective protection and continuity of service, Legrand offers state-of-the-art solutions, quick and easy implementation.



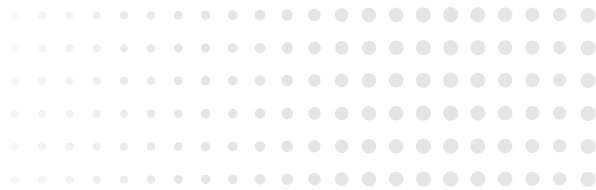

1. MCBs, ACBs & MCCBs

2. ELECTRICAL ENERGY METERING

3. MOTOR PROTECTION & CONTROL

4. REACTIVE ENERGY COMPENSATION

5. CABINETS AND ENCLOSURES

6. INDUSTRY PLUGS & SOCKETS

7. BTICINO POWER PRODUCTS
(Proudly Made In Egypt)



MCBs, ACBs & MCCBs

With DMX³ air circuit breakers, DPX³ or DRX moulded case circuit breakers, or DIN rail mounting circuit breakers, Legrand offers reliable, effective solutions that are easy to install.

RX³, TX³ and DX³ MCBs

MCBs and RCBOs, RCCBs and add-on modules, control and signalling auxiliaries, an extensive range of DIN rail mounting devices boasting a multitude of functions, suitable for all types of site.

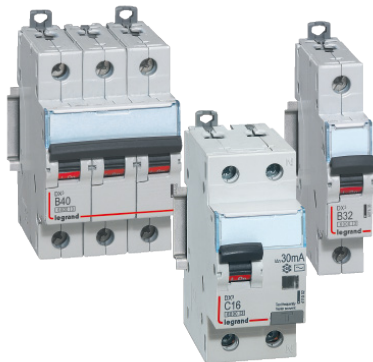

DPX³ MCCBs

DPX³ MCCBs are available in a wide range of ratings, versions, with innovative characteristics and functions, from 16 to 1600 A.



DMX³: ACBs up to 6300 A

Air circuit breakers (ACBs) up to 6300 A.



DRX and DRX-HP thermal magnetic MCCBs

DRX thermal-magnetic MCCBs have been designed to meet your essential requirements in terms of protection for electrical installations up to 630 A.



Automatic transfer switch control units

Control units for automatic transfer switching are used to change over supplies, manage a generator start or stop, control 1-, 2- and 3-phase supplies and also phase-to-phase and phase-to-neutral voltages.

For DPX³ MCCBs and DMX³ ACBs and CTX³ contactors.



Distribution

Copper or aluminium supply busbars and modular distribution blocks are designed to create distribution systems to suit your wiring practices and provide maximum safety and continuity of service.

Starline
A brand of



Electrical Energy Metering

Measurement, diagnostics and monitoring:
3 actions to apply to your energy consumption that will help you make real savings.

EMDX³ energy meters

Their role is to record the electricity consumed by a single-phase or three-phase circuit downstream of the electricity supply company's metering.



EMDX³ multi-function measuring units

The guarantee of accurate, regular measurement, combined with corrective actions, for optimum control of energy consumption and quality.



CX³ energy management system (EMS)

The purpose of the CX³ energy management system (EMS) is to supervise and manage a building's energy consumption, ensuring reliability and continuity of service, for optimum installation efficiency.



Motor Protection & Control

MPX³/CTX³/RTX³, uncompromising performance for motor protection and control.

MPX³ motor protection circuit breakers up to 100 A

Maximum efficiency in a smaller space. With just 4 case sizes, the MPX³ range of circuit breakers offers uncompromising performance and functionality for protecting motors up to 100 A.



CTX³ contactors and RTX³ thermal relays - 3 poles up to 800 A

For controlling circuits up to 800 A. A comprehensive range of ratings, control voltages, auxiliaries and accessories and full compatibility with MPX³ circuit breakers and RTX³ thermal relays.



CTX³ contactors - 4 poles up to 900 A

CTX³ contactors are also available in a 4-pole version from 20 to 900 A (AC1).

Conforming to standards: IEC 60 947-1, IEC 60 947-4-1. They can be equipped with auxiliary contact blocks, a time-lag module (CTX³ 4P 40 to 135 A) and an interlock module.



Reactive energy compensation

Alpes Technologies is a Legrand Group brand which specialises in reactive energy compensation and controlling the quality of electrical energy with a range of products to improve the energy efficiency of your installation.

Alpimatic automatic capacitor banks

Alpimatic capacitor banks are automatic banks with switching via electromechanical contactors.



Alpibloc fixed capacitor banks

Ready to use fixed capacitor bank assembly with circuit breakers.



Alpivar³ capacitors

Alpivar³ patented capacitors with vacuum technology are totally dry units with no impregnation or insulation liquid.



Cabinets and enclosures

You can choose from numerous cabinet and enclosure solutions (Practibox S, Drivia, XL³, XL³ S, Plexo³), ensuring you'll find the answer for any type of installation. Created with a simple modern design, they make it easy to wire up and operate your installations.

Practibox S cabinets

A well-designed range of cabinets, from 4 to 72 modules, with a timeless streamlined design which blends in harmoniously at home and in the workplace.



Drivia™ cabinets

Innovation at your service: 13 or 18 modules per row, the distribution board for residential and small commercial buildings.



Practibox³ flush-mounting distribution cabinets

Elegance and functionality: flush-mounting cabinets with 8 to 72 modules, 8/12 or 18 modules per row.



Convivio 3 - Phase Distribution Boards up to 250 A

Specially designed for the residential sector or small commercial and industrial buildings, the new Convivio range of 3-phase distribution boards can be installed in various type of buildings such as individual houses, villas, blocks of flats offices or commercial buildings, hotels, factories, warehouses.



XL³ 125 cabinets

XL³ 125 is the range of distribution cabinets with 18 modules per row, easy to install for maximum convenience and time saving.



XL³ 400 CABINETS

Fully extendable cabinets and enclosures providing a strong housing for assemblies. Capacity: 24 modules per row. Can be used with a cable sleeve.



XL³ 800 CABINETS

Provide a strong housing for distribution assemblies up to 800 A. Capacity: 24 or 36 modules per row and heights of 1050 to 1950 mm.



XL³ S enclosures

The XL³ S range of enclosures has been specially designed to make the panel builder's job easier.



XL³ distribution enclosures

XL³ cabinets and enclosures help you optimise the concept of Legrand product integration. Whichever enclosure you choose, and whatever your preferred way of working and the technical demands of your installations, you will find the answer to your requirements in the XL³ offer.



Plexo³ weatherproof cabinets

A range of IP 65-IP 09 weatherproof cabinets with numerous ingenious features that can save you time during setup and allow you to create different configurations.



Altis, Marina 2 & Atlantic industrial cabinets and enclosures

Thanks to our extensive offer of industrial cabinets and enclosures, Legrand can promise you'll find a suitable solution, for any type of site, even corrosive environments or sites subject to stringent climate requirements.



Viking 3 terminal blocks

High-quality connection, excellent mechanical strength, immediate identification, all these advantages make Viking 3 a benchmark range in the connection world.

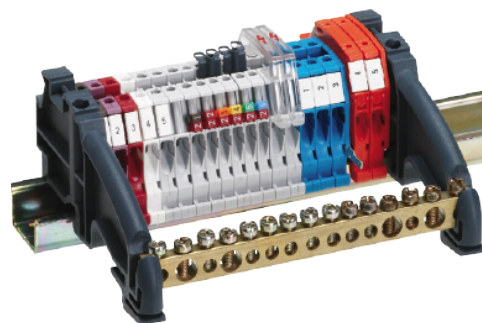



Industry Plugs & Sockets

Two ranges of industrial sockets and combined units for installations involving specific constraints related to weatherproofing, impact or temperature resistance, both indoors and outdoors.

P17 Tempra Pro industrial plugs & sockets and cabinets

The P17 Tempra Pro range of industrial sockets offers numerous benefits for optimum setup of installations and increased user safety.



Hypra industrial plugs & sockets and combined units

The Hypra range is recommended for harsh environments (dust, water splashes, etc.) such as food processing, silos and marine environments.





Power & Protection (Proudly Made in Egypt)

MCB

The new MCB BT DIN, characterized by the same power interruption for all calibration range, propose technical solutions and innovative features to ensure the highest level of protection in any situation.

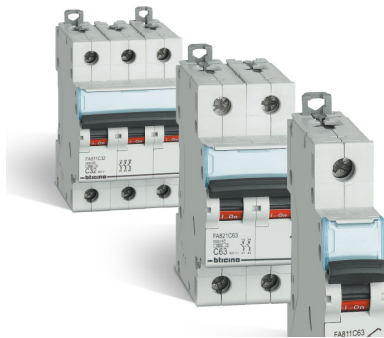

Safety Breaker

Overload protection & disconnect switch.

Flush mounting safety breaker 1P+N for Solida cover plates, 30A- 230V- 2.5KA (White Cover Plate Included)



Fuse Switch

Breaker 380V a.c. - with 26A fuses - ceramic body and moulded ivory top - with spare fuse holder



601



602



603





UPS PRODUCTS





1. SINGLE-PHASE UPS

2. THREE-PHASE INVERTER

3. UPS ACCESSORIES

SINGLE-PHASE UPS

Consumer & Soho

Compact, easy to install and configure. They provide total, reliable protection of the installation, an excellent quality/price ratio and guarantee of a lasting investment.

KEOR DC

Single-phase UPS for Modem/Router and connected devices



NEW KEOR MULTIPLUG

Single-phase line interactive UPS with power ratings of 600 and 800 VA



KEOR SP

Single phase line interactive UPS with power ratings of 600-800-1000-1500-2000 VA



KEOR PDU

800VA for cabinet applications 19 inch wall RACKS



NIKY S

VI single-phase line interactive UPS systems from 1000 a 3000VA with perfectly sinusoidal output



KEOR LINE RT

VI single-phase line interactive UPS systems from 1000 a 3000VA with perfectly sinusoidal output



Conventional

On-line double conversion UPS with DSP microprocessors for precise, constant control of all measurements and of the power factor correction circuit (PFC). Transformer-free technology for high quality energy output with up to 96% efficiency.

DAKER DK PLUS

VFI single-phase on-line double conversion convertible UPS systems from 1kVA to 10kVA



KEOR LP

Single-phase UPS on-line double conversion from 1 to 3kVA



KEOR S

Single-phase conventional UPS on-line double conversion from 3 to 10 kVA



Modular

Modular UPS enable the power supply to be sized exactly to requirements, without precluding any future expansion. They are made up of “standard” modules that can be added to existing configurations to increase their power or backup time.

MEGALINE

MEGALINE VFI single-phase on-line double conversion modular UPS systems from 1250VA to 10kVA



MEGALINE RACK

VFI single-phase on-line double conversion modular UPS systems from 1250VA to 10kVA





THREE-PHASE

CONVENTIONAL

On-line double-conversion UPS with DSP microprocessor for accurate and constant control of all measurements and PFC input power factor correction). Electronics without output transformer (OTL) for the highest quality of the output voltage with an efficiency of up to 96%.

KEOR COMPACT

Is a three-phase uninterruptible power supply on-line double converter 10-15-20 KVA.



KEOR T EVO

Is a three-phase uninterruptible power supply, On-line Double Conversion able to provide with continuity the rated power of 10-15-20-30-40-60 kVA.



KEOR HP - TRANSFORMER BASED

Is a three-phase uninterruptible power supply On-line Double Conversion with PWM highfrequency and with the possibility to be connected in parallel to have N+X redundancy up to total 6 units.



KEOR HPE - TRANSFORMERLESS

Is a three-phase uninterruptible power supply On-line Double Conversion with 3-Level IGBT technology, PWM high frequency and with the possibility to be connected in parallel to have N+X redundancy up to total 6 units.



KEOR XPE

Is a complete Scalable UPS System based on 250 kVA or 300 kVA power units and can reach up to 2.1 MVA nominal power.

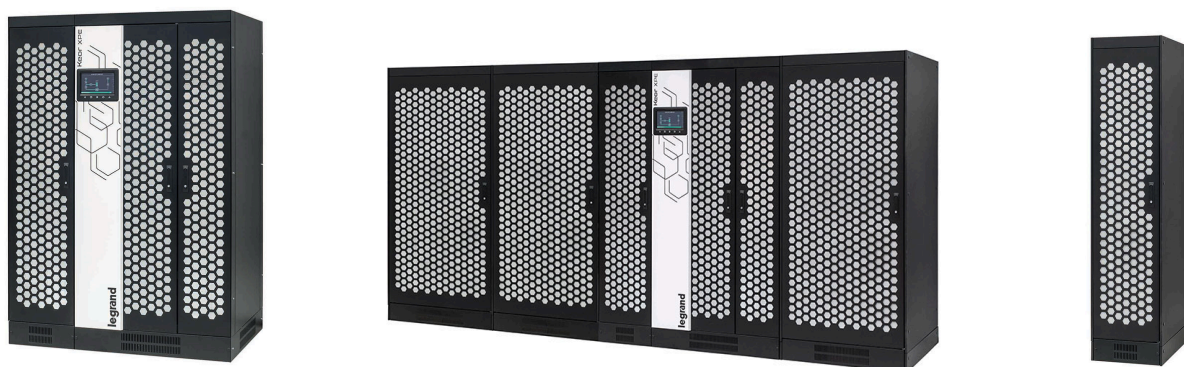

MODULAR

Modular UPS enable the power supply to be sized exactly to requirements, without precluding any future expansion. They are made up of “standard” modules that can be added to existing configurations to increase their power or backup time. Their innovative modular system, provides the highest possible level of redundancy.

TRIMOD MCS

The CPS (Central Power Supply) TRIMOD MCS are single-phase and three-phase central power supply systems with high frequency PWM technology, On Line Double Conversion type



KEOR MOD

Keor MOD is a three-phase uninterruptible power supply on line double conversion with PWM High-Frequency technology, modular architecture with the possibility to have N+X redundancy.



TRIMOD HE

TRIMOD HE UPS is a three-phase uninterruptible power supply on line double conversion with PWM High-Frequency technology, modular architecture with the possibility to have N+X redundancy.



UPS ACCESSORIES

COMMUNICATION ACCESSORIES

Network interfaces, for remote control of UPS. Sensors for monitoring the ambient temperature and humidity. Communication and supervision software for accessing the operating parameters of the UPS, carrying out full diagnostics and configuring specific functions.

NETWORK INTERFACES

The network interfaces for managing UPS do not require any external software. They include a proprietary system capable of real-time control of the operation of the UPS and managing numerous events (power failure, overload, bypass, problem, etc.) and as a result executing a series of actions



SENSORS

The range consists of two different types of sensors, according to the type of connection to the UPS.



SOFTWARE

The management software provides two main functions:
UPS management and control: UPS Communicator and UPS Management Software;
UPS supervision (monitoring and remote control): RCCMD, UNMS.

BATTERY CABINETS

Universal battery cabinets for all three-phase Legrand UPS from 10kVA up to 800kVA power range.



GREEN'UP

ACCESS & PREMIUM CHARGING SOLUTIONS FOR ELECTRIC VEHICLES





Ready to install pack and Green'up Access kit

The ready to install pack consists of a heavy-duty socket identified for electric vehicles + a fixing base + an RCBO.

8 to 16 A charging, in complete safety, of all electric vehicles with a mode 1 or mode 2 cable. Detection system patented by Legrand: vehicles detect the secure Green'up infrastructure and select the maximum power that can be supplied by the socket, resulting in a shorter charging time.



Flush-mounting Green'up Access sockets

With its IK 10 protection giving it excellent resistance to harsh environments, the Green'up Access socket is perfect for use in public car parks and lock-ups.

8 to 16 A charging of all electric vehicles with a mode 1 or mode 2 cable, regardless of how much charging power is required by the vehicle (detection system patented by Legrand).



Plastic Green'up Premium charging stations

The Green'up Premium charging station is used for charging vehicles in mode 2 and mode 3. With its native Bluetooth connection it can be used to control charging locally via the EV CHARGE application. When connected to the IP or Wi-Fi network with the communication kit (optional), it allows remote control from a smartphone, tablet computer or PC. Wall fixing or floor standing (optional).



Metal Green'up Premium charging stations

The Green'up Premium charging station is used for charging vehicles in mode 2 and mode 3. Interoperable charging station for easier management: it can be controlled by a charging company and easily integrated in the car park operator's billing system.

Payment for the electricity used can be added to the cost of parking in the space. Wall fixing or floor standing (optional).



Managing standard charging

Green'up Premium charging stations offer the option of managing charging locally thanks to the integrated Bluetooth: charging station configuration and management using a smartphone or tablet via the app (compatible with IOS or Android).

Available functions: daily charging program, display of charging station operation, charging station activation/deactivation, log, consumption monitoring with cloud data storage, firmware updates.



Managing charging with the communication kit

The communication kit (optional) can be used for managing functions and remote configuration of Green'Up Premium charging stations, on a smartphone, tablet or PC via IP (RJ 45) or Wi-Fi. Combined with centralised or stand-alone readers, it controls access via an RFID card.

A bank of charging stations can be managed via the Legrand web server.



Ecotap fast charging

Front-running Dutch player, specialist in alternating and direct-current charging stations for electric vehicles



STRUCTURED CABLING

AND SOLUTIONS FOR LANS
& DATACENTERS





1. DATA CENTER

2. STRUCTURED CABLING

3. AUDIO/VIDEO SOLUTIONS



Data center: Services and Solutions

Housing Solutions

Perfectly adapted solutions for installing servers, switches, patch panels, routers and storage equipment.

Racks and cooling

A comprehensive range of solutions with active components such as air conditioning units, fans, etc. An extensive range of solutions for air separation, air guidance and airflow management which also provide passive cooling.



Micro Data Centre - MiniCube

Pre-configured and truly plug-and-play compact solution comprising all needed systems :-
Housing , Power Supply , Monitoring and Cooling

Structured cabling

A complete global solution for both Copper and Fiber systems that perfectly address the key challenges for digital networks : performance , scalability and efficiency



Power distribution

ZERO-U & 1-U PDUs
 Raritan PX Intelligent PDUs
 Environment Sensors
 Rack Transfer Switches
 Branch Circuit Monitor
 DCIM Monitoring



Cable management

Cablofil steel wire cable tray:
 The most innovative complete wiremesh cable tray solution on the market.
 LCS³ Fiber Raceway cable tray:
 The ideal cable tray solution for distributing digital data in data centers.

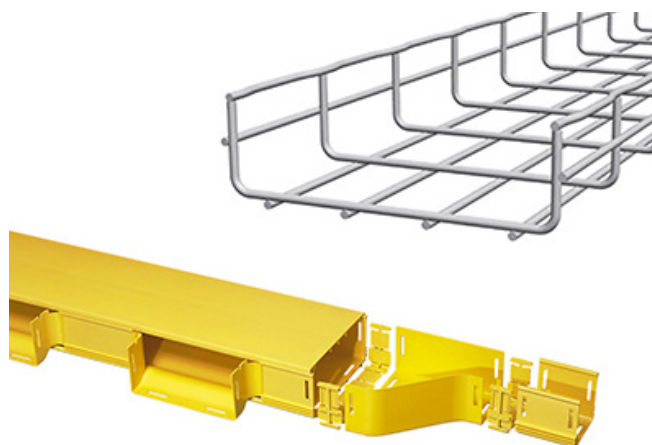

Starline Busway

Supplying the highest amperage of the Starline Track Busway systems, the 250-1250 series powers many of today's largest mission critical facilities. One of the main benefits of Starline is that it is an overhead power distribution system, meaning no jungle of cables and whips under the floor obstructing air flow. Also, the continuous access slot along the bus gives data centers the power to easily expand or reconfigure operations.

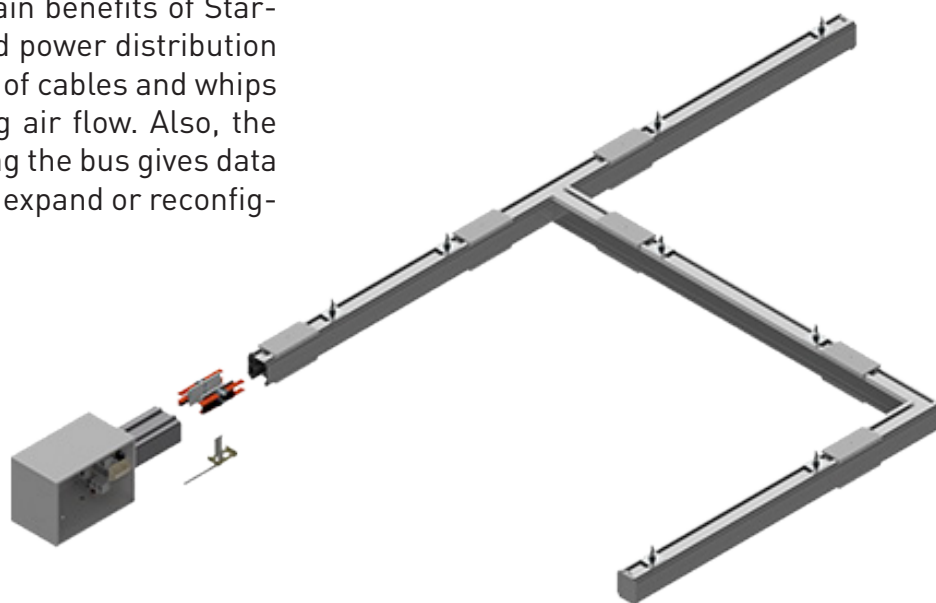

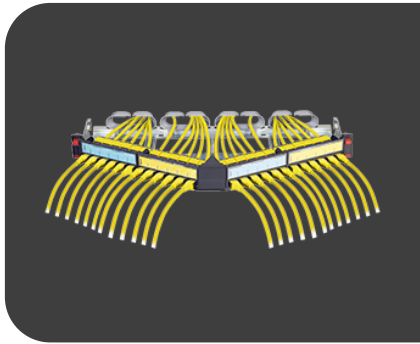

Structured Cabling & Solutions for LANs

LCS³ Enclosures and Accessories

The LCS3 cabling cabinet offer is suitable for all your projects, from the smallest to the large- scale highly critical ones.

Copper LCS³ structured cabling

Thanks to a comprehensive offer, the copper LCS3 system guarantees performance at every level.

Available in all categories (Cat5e , Cat.6, Cat.6A and Cat.8)

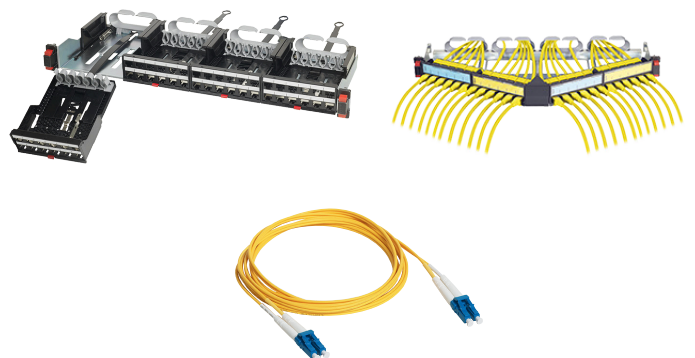

Fiber Optic Structured Cabling

The LCS³ fibre optic offer consists of cables , modular panels and associated cassettes, fibre optic blocks and drawers as well as a variety of connection solutions.





Audio/Video Solutions

The flexible choice

Legrand's audio/video offer comprises a wide range of products that make it easy to extend or refurbish existing installations. It is ideal for classrooms and meeting rooms as it can be used to stream digital video between a source and a receiver.



A variety of connections to suit every need

HDMI, VGA, RJ 45, DisplayPort, USB-A, USB-C cables... our connections are effortlessly integrated in the spaces where you work, where you go online and where you share information.



CABLE MANAGEMENT

& POWER AND DATA DISTRIBUTION

Systems for routing power and data, protecting electrical installations, and improving comfort in buildings.

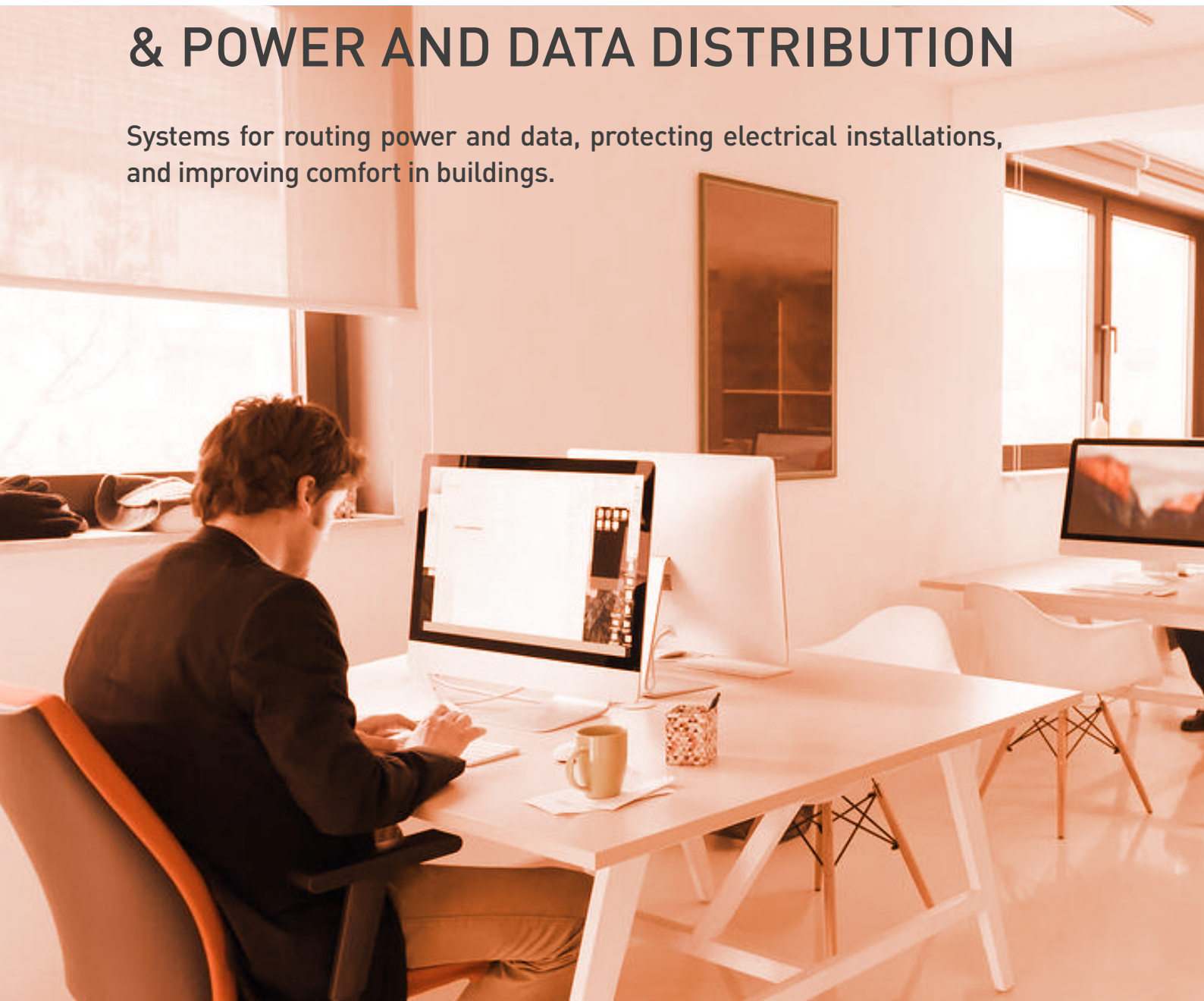



**1. POWER AND DATA DISTRIBUTION
VIA THE CEILING**

**2. POWER AND DATA DISTRIBUTION
THROUGH THE FLOOR**

**3. POWER AND DATA DISTRIBUTION
ON THE WALL**

**4. DELIVERING POWER AND DATA
TO THE WORKSTATION**

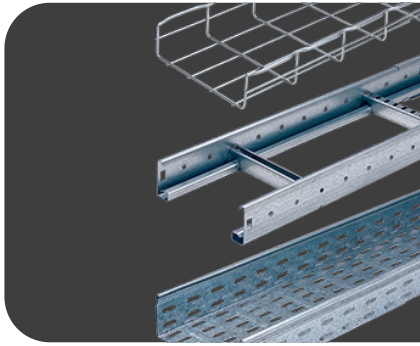

Power & Data Distribution via the Ceiling

Cablofil Wiremesh Cable Trays

The Cablofil wiremesh cable tray has the most certifications in the Legrand range.



P31 Cable Trays

Robust, efficient, certified products. Ingenious design, quality, excellence, fire resistance are the main attributes of the new range of P31 cable trays.



Cable Ladders

Unfailing strength: increased capacity for heavy loads up to 100 kg/m for a 6 m span.

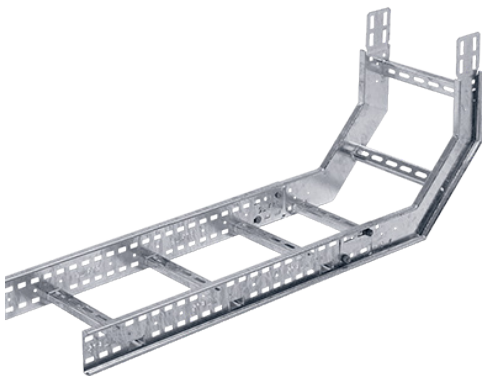

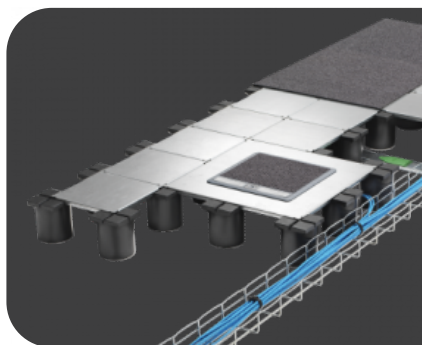

Power & Data Distribution through the Floor

The Soluflex floor system

The Soluflex cable floor system is a raised access floor, a cabling system and a connection technology all in one.

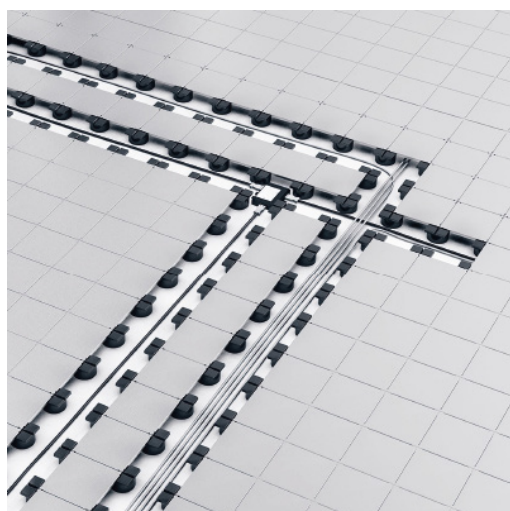

Cablofil Wiremesh Cable Trays

Thanks to Cablofil the cables are visible and permanently accessible to make maintenance operations easier.

Cablofil's wiremesh structure allows easy insertion of cables at any point along the run.

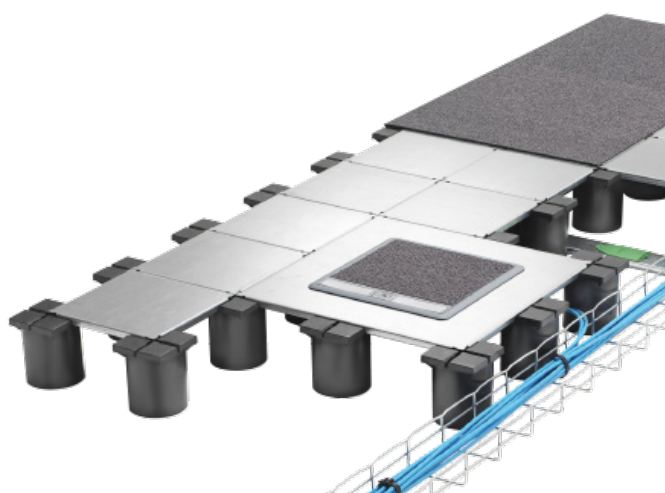



Power & Data Distribution on the Wall

DLPlus mini-trunking and skirting

DLPlus mini-trunking and skirting offers you solutions for easier refurbishment. Various fixing methods, with or without a central divider to separate the cables.



DLP-S distribution mini-trunking

A comprehensive range to cover essential requirements in refurbishment work. Thanks to its special adaptor, it can take Forix wiring accessories and provide a neat and attractive appearance.



PVC or aluminium DLP trunking

DLP trunking is available in a PVC version with a flexible cover or in an aluminium version. The flexible cover and various different finishing accessories make installation easier.



PVC DLP-S trunking

DLP-S trunking is designed to satisfy all your site requirements. It is made of PVC with a rigid cover and fixed finishing accessories, and is available in both snap-on and universal versions.





Delivering Power & Data to the Workstations

Floor boxes

Adaptability, modularity and convenience are the key features of the new offer of modular floor boxes.



Columns & mini-columns

An extensive range which covers every need in terms of connectivity, size, cabling capacity and finish throughout the world for different types of site.



Pop-ups

Our sleek new ergonomically designed pop-up boxes provide real ease of use and quick connection for mobile applications: laptops, mobile phones, audio and video systems, etc.



Desk grommets

Ingenious and ergonomically designed, the desk grommet system provides access to power, the data network or the opportunity to charge your mobile phone.



Multi-outlet solutions

Plugging in, (re)charging and organizing connections at will according to activities and spaces: nothing could be easier with our range of multi-outlet solutions.



Desktop and meeting room multi-outlet extensions

Available ready to use or as a customisable solution, our desktop and meeting room multi-outlet extensions provide a high degree of flexibility and convenience for both mobile and desk-based users.



Office modules

Discreet power and data distribution: office modules are used on their own or as an intermediate point for supplying desktop multi-outlet extensions.





LIGHTING CONTROL

Put to an end to wasted energy: find out more about our products and services for better energy efficiency in buildings.





Lighting Management

Self-contained detectors

Ideal in an individual office or in open space, the flush-mounted or wall-mounted lighting management sensor combines infrared and ultrasonic technologies to detect the slightest movement.



BUS/KNX, SCS & DALI lighting solutions

Legrand brings energy efficiency, convenience and flexibility to every space, that needs no upgrading as the building evolves.



CP Electronics

CP Electronics products help companies to reduce their operating costs and carbon footprint through cost-effective lighting, heating and ventilation control. A drive to bring high quality, innovative products to market has led to:

- An extensive range of patents.
- A large international client base.
- An exceptional reputation for reliability in this highly specialized field.





WIRING DEVICES

An extensive range of finishes and functions associated with digital and conventional technologies, the assurance of finding a solution that best suits your need



A vertical red sidebar on the left side of the page, containing a blurred image of a room with a bookshelf and a ceiling light fixture.

1. Legrand Products

2. Bticino Products

3. Bticino Products (Proudly Made in Egypt)

LEGRAND PRODUCTS

- Arteor
- Defineo
- Céliane
- Belanko S
- Niloe
- Plexo™

Arteor™ A Touch of Artistry

Arteor, the international range of beautiful wiring devices transforms the entire look of any home. Elegant and minimalistic, Arteor is made to transcend time.



Defineo

With its sleek design, elegant curves and choice of 4 colours, DEFINEO blends in seamlessly in the majority of houses or flats.



Céliane™

A marriage of form and function, a wide choice of materials and colours, innovative functions to improve the wellbeing of everyone in the home.



Belanko™ S

With Belanko™ S, simplicity meets style.



Niloé™

Flush-mounting wiring accessories for the home, for both new-build and refurbishment projects, which are innovative by design.



Plexo™

In white or grey colours and ensuring maximum flexibility during installation, the Plexo offer is available in both complete and modular versions.



Mosaic™

Mosaic has been revamped to offer even greater modularity and versatility. A wall-mounted and off-wall system which is more modular, more connected, even more robust and quick to install.



Soliroc™

The new IK 10 Soliroc guarantees all-out robustness in exposed or unsupervised premises, both indoors and outdoors.



Bticino Products

- Living Now
- Classia
- Matix

Living Now

Living Now is the new Living generation. A timeless icon which combines the linearity of a unique design with the simplicity of Smart technology.



Classia

A modern pure shape, defined by an accurate outline which contrasts with a gently curved surface. The frame gives a unique touch to your switch.



Màtix™

5 collections for a very personal style perfectly in keeping with contemporary style trends.



Bticino Products (Proudly Made in Egypt)

- Matix Edge
- Solida
- Forma Max

Matix Edge

Pure lines flowing into a slightly curved surface convey all the typical lightness of contemporary design by BTicino.



Solida

mechanism with white or ivory gloss finish, and illuminated switches. Cover plates with smooth shapes.

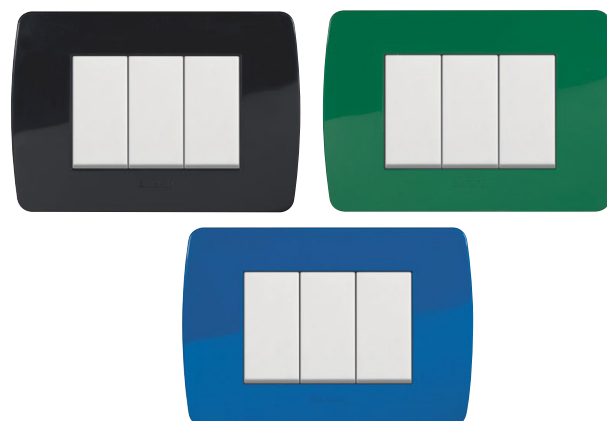

Forma Max

The new plate is characterized by a very taut surface that connects on the sides with a nice curve.

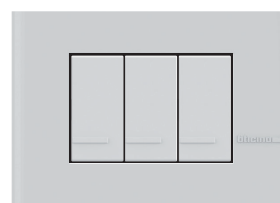

SMART HOME





1. Legrand with Netatmo

2. Connected Door Entry System

3. Netatmo Security Products

4. Smart Electrical Panel



Legrand with Netatmo: A touch of Genius

Designed to make any house more individual, convenient and secure, Arteor with Netatmo adds a touch of smartness to your home.

This modular, WiFi enabled collection of connected switches and socket outlets lets you shape your projects very easily to fit your individual requirements.

Available in Arteor & Living Now ranges

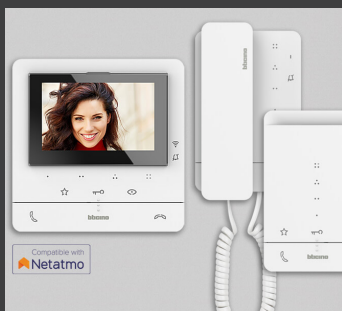
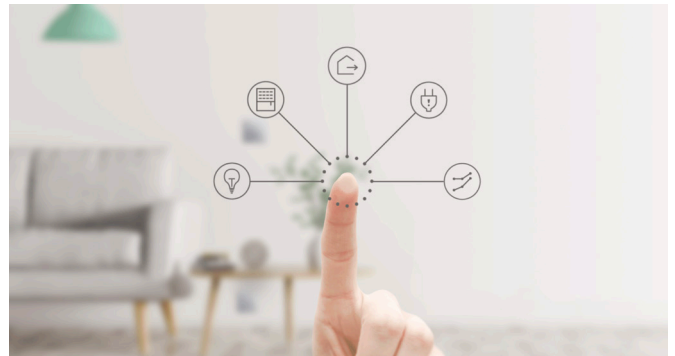

Connected Door Entry System

Simplify your daily life with the connected video door phone!

No more missed visits and deliveries: with Bticino Classe 300EOS with Netatmo and Classe 100X connected solutions, you keep in touch with your home at all times.

I can see who is ringing and I can answer. On the road, on vacation, in the office or even busy at home, I can see my visitor and interact with him/her remotely.





Netatmo Security Products

Leave your home with peace of mind.

Netatmo has thought of everything to provide your home with complete smart protection: security cameras, alarms, sensors, smoke alarms, etc. giving you total peace of mind, at last.

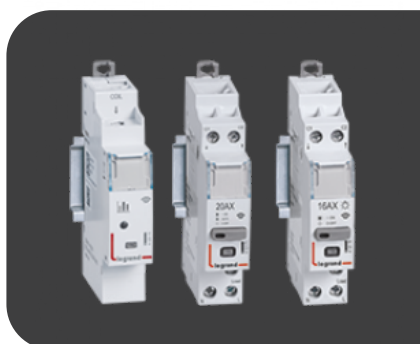

Smart Electrical Panel

An interface that is easy to wire up and install

Compatible with all other “with Netatmo” connected products, the EMDX3 with Netatmo Gateway Module allows you to start a connected installation from your electrical panel and acts as an interface between your router and connected wired products. Its fixed base and removal section make it easy to wire up and install. A single interface is enough to control the whole house.



CONTROLLING THE INSTALLATION





1. Audio & Video Door Entry Kits

2. MYHOME Control Units

3. Chimes

4. Complementary Products (Proudly Made In Egypt)



Audio & Video Door Entry Kits

From private houses to large complexes, perfect intercom solutions which meet your needs whatever the project, combining security and convenience.

Now the standard is connected

BTicino renews the range of Classe 100 indoor units by introducing Wi-Fi connectivity in the standard video door entry system offer. The result is a range of video and audio indoor units with a modern and elegant design, capable of meeting all installation needs. Wi-Fi connectivity in the standard video door entry system offer. The result is a range of video and audio indoor units with a modern and elegant design, capable of meeting all installation needs.



The High performance system offer

D45 SYSTEM BTicino simplifies installation in residential complexes with large numbers of apartments. The use of UTP cables and RJ45 connections for all the devices provides quick, easy installation for both backbone and riser devices. The system is suitable for the varied requirements of systems of different sizes on risers or TCP/IP networks, ensuring maximum cost saving.



Full IP Solutions for Residential Complexes

FULL-IP SYSTEM BTicino is the ideal solution for large residential complexes with numerous apartments.



374005



My HOME_Up

My HOME_Up is the home automation solution, based on BUS technology with 2-wire twisted pair, designed to meet the different needs of:

- comfort, to control lights, shutters, temperature and music in any environment in a personalized way;
- security, to avoid unwanted intrusions, by integrating the alarm system and the video camera;
- consumption and power control, to obtain energy savings and to avoid overload blackouts.

Chimes

Easy to install and reliable, these are ideal solutions for both the residential and small commercial sector. Install your radio chime wherever you want with your favorite tune!



Complementary Products (Proudly Made In Egypt)

- Duton
- Back Box
- Lamp Holder

Duton The classic sound

A classic and elegant design, that is most widely used for its shape and also for its unique sound which is like piano tone.



Back Box Safe and reliable installation

The ease of installation and the range of available accessories make wiring easy and allow for total side by side installation of the boxes

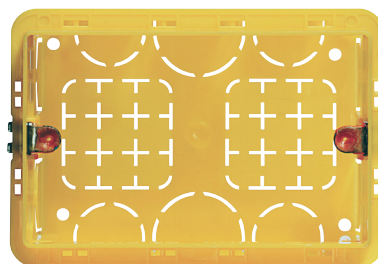

Lamp Holder Long life installation

Lamp Holder gives you high performance and according to its 100 watt ,it considers as the best choice to complete the meaning of comfortable in your home by carry some of electrical loads.

It has a curved shape with the larage back space for bending extra cabling, and also it has stylish design which is covered





COMPLIMENTARY PRODUCTS

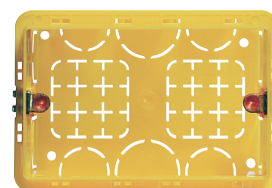

HOSPITALITY BUILDING

Legrand's control system can be used to program different scenarios in the room in order to live a unique, innovative experience.





1. Guest Room Management System

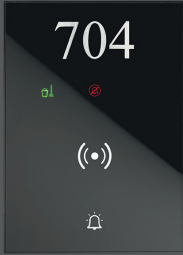

Guest Room Management System

CUSTOMIZE YOUR GUESTS' EXPERIENCE

A brand new set of dedicated room controllers. Complete, user-friendly, customizable controllers along with touch technology make these products the most innovative solution for hotel room management. These new devices are developed and designed to work with SCS-BUS.

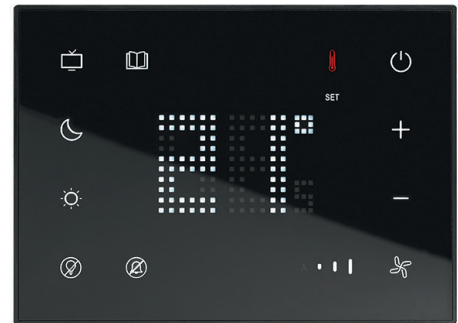





HEALTH CARE SOLUTIONS

Customized solutions for retirement homes and hospitals, and also for schools and non-medical establishments.



Bus Nurse Call system

Legrand proposes a new and innovative concept for health-care facilities, based around the patient's room, which combines assisted living, hygiene, and energy efficiency. It guarantees comfort and security for inpatients, effective care for the care staff, and a high degree of maintainability for the operator.





EMB Electrical Industries S.A.E.

Headquarter office:

Pyramids Heights Office Park
KM 22 Cairo - Alex. desert road
Building 9C, 12556

Tel.: +202 3536 0000

Fax: +202 3536 0001

www.legrand.com.eg